

ASSEMBLY INSTRUCTIONS

GS-28F-S0003

Figure 1 Type A, Style N

Part Numbers:

NSN 7110-01-516-0408 NSN 7110-01-516-0398 NSN 7110-01-516-0399

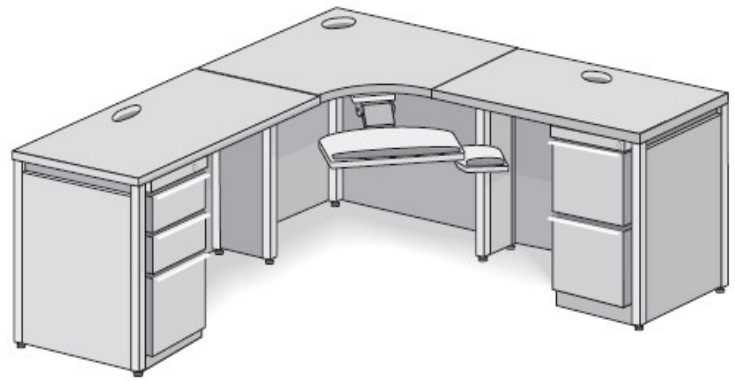
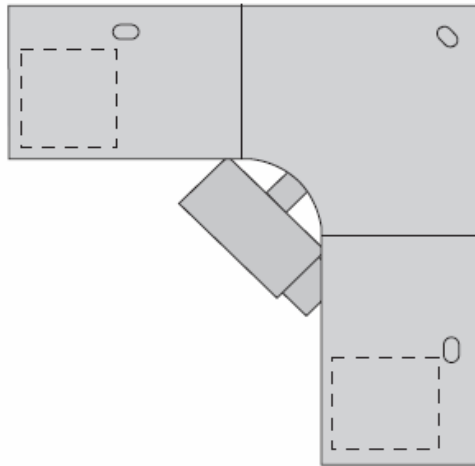

Basic Tools Required for Assembly

Phillips Screwdriver



Tape Measure

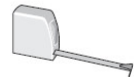

(Optional Tools)

Drill/ Screw Gun



Rubber Mallet



Level



Box Cutter



Some Steps may require a Second Person for Assistance



NOTE: Please check to make sure all required pieces are present before assembling.

Having technical difficulties or missing parts? Please call 866-450-8160



U.S. General Services Administration

Types of Screws Referred to in these Instructions

Panhead Screw

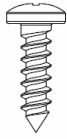

#10 x 3/4"

Black Screw



#10 x 1/2"

Machine Screw



#10-24 x 3/4"

**Washer Head
Black Screw**

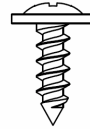

#8 x 1/2"

Assembly Parts

Worktop Surface

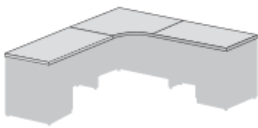

End Panel



Modesty Panel

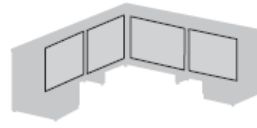

Rear Post Leg

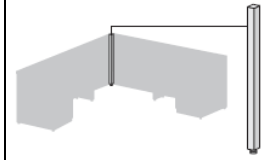

**Vertical Wire
Manager**

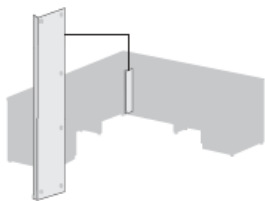

**Horizontal Wire
Manager**

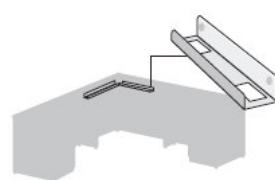

Bridging Bracket

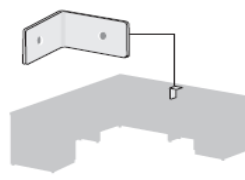

Leveling Glide

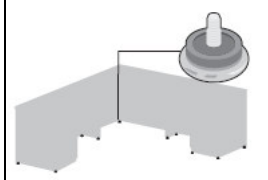

Your order is composed of the following manufacturer's part numbers. The manufacturer's part numbers are printed on a white label on the edge of each box.

Quantity	Part Number	Description
1	DSCC3M-24-36-FMHE	Corner Desk, 24x 36
1	ARK-SS	Keyboard Arm
1	RADTRAYPM	Keyboard Tray & Mouse Tray
2	DSRS3M-24-36-FMEP	Return, 24x 36
1	ESP20BM-R	Pedestal 2- box/ 1-file
1	ESP20FM-R	Pedestal 2- file
2	BDD	Box Drawer Divider
2	LC1	Lock Core Kit

Complete Workstation Components

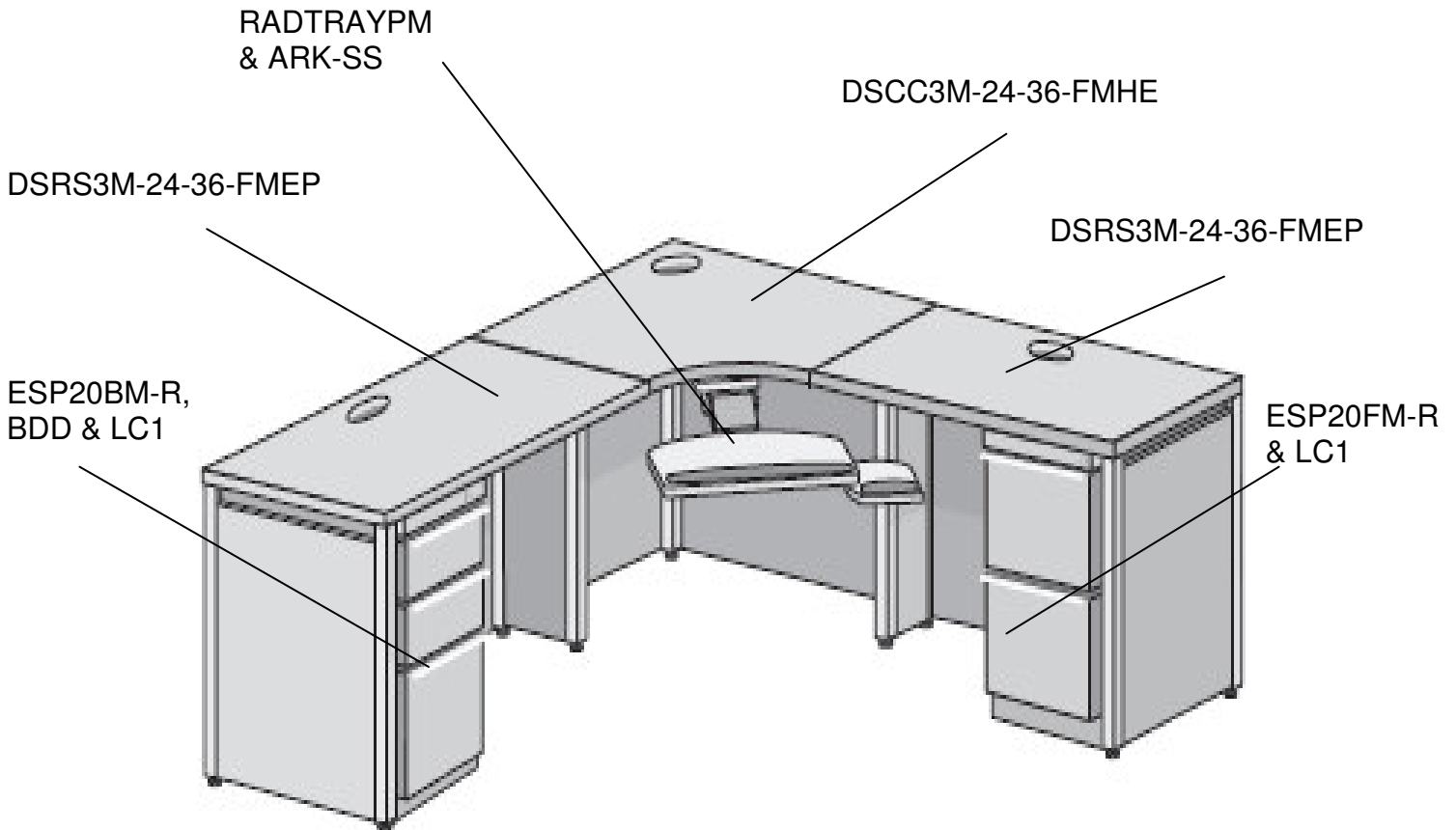

Corner Desk Assembly Instructions

NOTES: Corner Desks are not intended for “stand-alone” use and must be attached to at least one Return Surface or Bridge Top.

1. Locate box marked DSCC3M-24-36-FMHE/ Corner Desk.
2. Unpack box and lay all parts and hardware on a soft surface (for example, carpet or cardboard).
3. Locate the Worktop Surface (top part of the desk). Position the laminate or finished exterior of the work surface face down on the soft surface. Predrilled holes will face up toward the ceiling.
4. Locate one 9” End Panel. Attach End Panel to the work surface using a screwdriver or drill to insert two #10-24 x 3/4” machine screws into the metal inserts (inserts are silver in color and embedded in the wood) positioned on the work surface.
5. Locate the Modesty Panel, (modesty panel has three predrilled holes on the ends). Attach the Modesty Panel to End Panel with three #10 x 1/2” black screws using a screwdriver or drill.
6. Attach the first Modesty Panel to the metal inserts located on Worktop Surface with four #10-24 x 3/4” machine screws using the screwdriver or drill.
7. Locate the Rear Post Leg (Corner Post), position so the predrilled holes are facing inward towards the Modesty Panel. Attach the Rear Post Leg to the Modesty Panel using #10x 1/2” black screws with a screwdriver or drill.
8. Locate the second Modesty Panel, and attach to the Rear Post Leg with #10x 1/2” black screws using a screwdriver or drill.
9. Vertical Wire Managers must be installed at this time. To attach Vertical Wire Managers to the Modesty Panel, use the #10x 1/2” black screws with a screwdriver or drill.
10. Attach the second Modesty Panel to the Worktop Surface using a screwdriver or drill and four #10-24 x 3/4” machine screws into the metal inserts. (As in Step 6)
11. Locate the second End Panel, attach End Panel to the Modesty Panel using a screwdriver or drill to insert three #10x 1/2” black screws. (As in Step 5)
12. To attach the End Panel to the Worktop Surface, use a screwdriver or drill to fasten two #10-24 x 3/4” machine screws into the metal inserts positioned on the Work Surface
13. Locate the Horizontal Wire Managers. Use a screwdriver or drill to screw two #10x 1/2” black screws for each Wire Manager onto Modesty Panels.

You have now completed the Corner Desk Unit assembly.

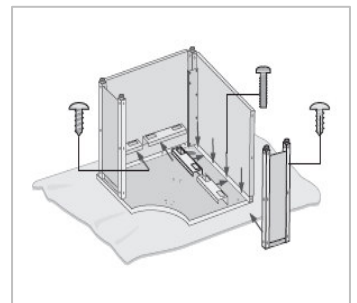
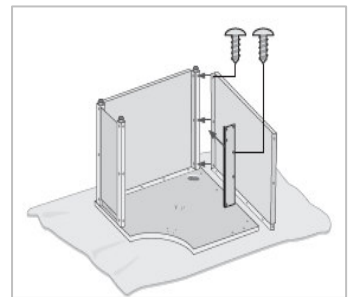
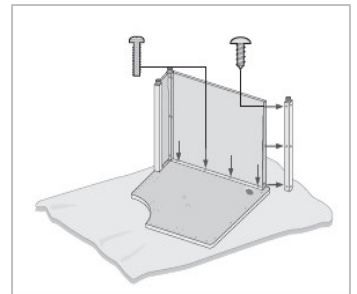
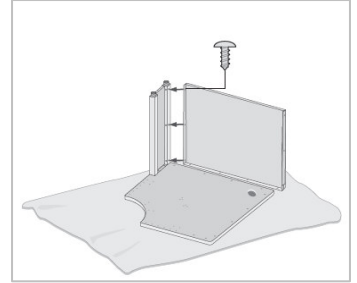
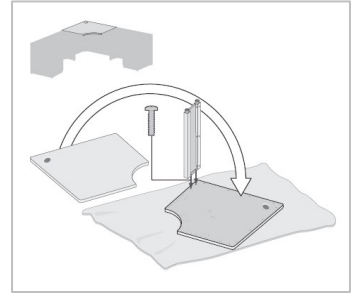

Keyboard & Keyboard Accessories

14. Now, locate the boxes marked as RADTRAYMP/ Keyboard Tray & Mouse Tray and ARK-SS Keyboard Arm. Unpack boxes.
15. To assemble keyboard Tray and Keyboard Arm, use supplementary instructions & template provided in the box.

After you have installed the Keyboard Arm, Keyboard Tray to the Corner Desk, proceed to adjust Leveling Glides.

Adjust Leveling Glides

16. At this time, the Leveling Glides should be adjusted the same amount in order for the Worktop Surface to be leveled.

Turn Desk Upright

17. Then turn the desk upright (legs should be on the ground). Adjust level glides if needed so that desk is level and does not rock.

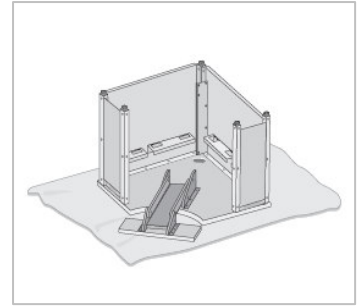

Left Return Assembly Instructions

NOTES: Return Desks are not intended for “stand-alone” use and must be attached to at least one Corner Desk, Return Surface, Desk or Bridge Top.

1. Locate the box marked DSRS3M-24-36-FMEP/ Left Return.
2. Unpack the box and lay all parts and hardware on a soft surface (for example, carpet or cardboard).
3. Locate the Worktop Surface (top part of the desk) with a 3” oval hole. Position the laminate or finished exterior of the work surface face down on the soft surface with the 3” oval hole opposite of you.

Left Return Assembly

4. Locate one End Panel and one Modesty Panel, (modesty panel has three predrilled holes on the ends). Position the Modesty Panel next to the 3” oval hole then position the End Panel to the right of the Modesty Panel.
5. Attach the End Panel to the Worktop Surface, align holes in End Panel with predrilled holes in the work surface. Attach with three #10-24x 3/4” machine screws using a screwdriver or drill.
6. Attach the Modesty Panel to the Worktop Surface, align holes in Modesty Panel with predrilled holes in the work surface. Attach with four #10x 1/2” black screws using a screwdriver or drill.

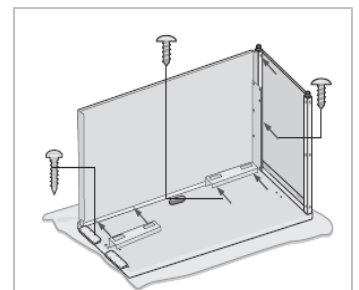
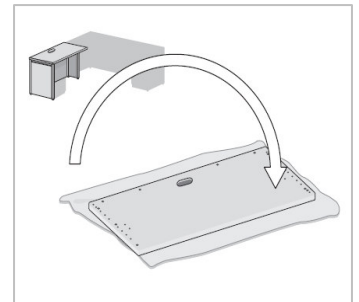

Then attach the Modesty Panel to End Panel with three #10x 1/2" black screws using a screwdriver or drill.

7. Now, the Vertical Wire Managers must be attached to the right side of the Modesty Panel on the Left Return using two #10x 1/2" black screws, with a screwdriver or drill.
8. Place the two Horizontal Wire Managers on the edge of the Modesty Panel and close to the Worktop Surface. Attached to the Modesty Panel with two #10x 1/2" black screws each.

Adjust leveling glides

9. At this time, the Leveling Glides should be adjusted the same amount in order for the Worktop Surface to be leveled.

Turn Desk Upright

10. Then turn the desks upright and align the two edges with a flat Bridging Brackets from underneath the work surface. Adjust level glides if needed so that desk is level and does not rock.

Attach to corner

11. To attach the Return Surface Worktop to the Corner Desk, use two flat bridging brackets and eight #10x 3/4" panhead screws (for each bracket).
12. Connect the Return Modesty Panel to the Corner Desk End Panel with two #10 x 1/2" black screws.



(TIP) You may need the assistance of a second person to align the two edges as you screw the flat Bridging Brackets from underneath the work surface.

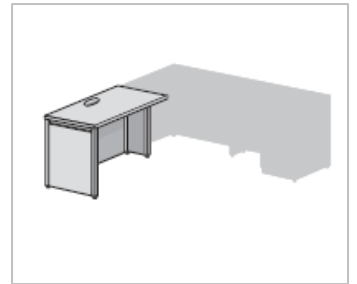
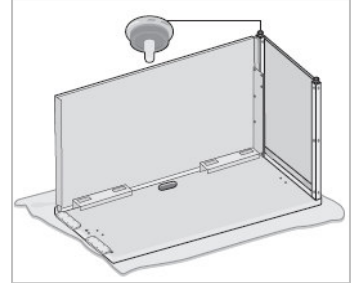
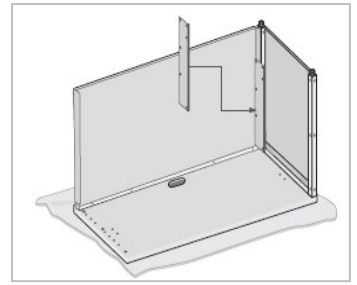

Right Return Assembly Instructions

NOTES: Return Desks are not intended for "stand-alone" use and must be attached to at least one Corner Desk, Return Surface, Desk or Bridge Top.

1. Locate the box marked DSRS3M-24-36-FMEP/ Right Return.
2. Unpack the box and lay all parts and hardware on a soft surface (for example, carpet or cardboard).
3. Locate the Worktop Surface (top part of the desk) with a 3" oval hole. Position the laminate or finished exterior of the work surface face down on the soft surface with the 3" oval hole opposite of you.

Right Return Assembly

4. Locate one End Panel and one Modesty Panel, (modesty panel has three predrilled holes on the ends). Position the Modesty Panel next to the 3" oval hole then position the End Panel to the left of the Modesty Panel.
5. Attach the End Panel to the Worktop Surface, align holes in End Panel with predrilled holes in the work surface. Attach with three #10-24x 3/4" machine screws using a screwdriver or drill.

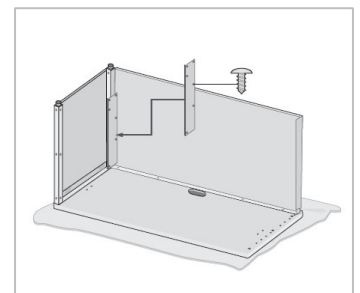
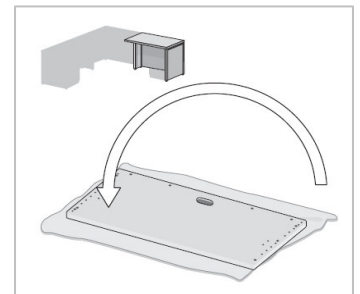

6. Attach the Modesty Panel to the Worktop Surface, align holes in Modesty Panel with predrilled holes in the work surface. Attach with four #10x 1/2" black screws using a screwdriver or drill. Then attach the Modesty Panel to End Panel with three #10x 1/2" black screws using a screwdriver or drill.
7. Now, the Vertical Wire Managers must be attached to the left side of the Modesty Panel on the Right Return using two #10x 1/2" black screws, with a screwdriver or drill.
8. Place the two Horizontal Wire Managers on the edge of the Modesty Panel and close to the Worktop Surface. Attached to the Modesty Panel with two #10x 1/2" black screws each.

Adjust leveling glides

9. At this time, the Leveling Glides should be adjusted the same amount in order for the Worktop Surface to be leveled.

Turn Desk Upright

10. Then turn the desks upright and align the two edges with a flat Bridging Brackets from underneath the work surface. Adjust level glides if needed so that desk is level and does not rock.

Connect to corner

11. To attach the Return Surface Worktop to the Corner Desk, use two flat bridging brackets and eight #10x 3/4" panhead screws (for each bracket).
12. Connect the Return Modesty Panel to the Corner Desk End Panel with two #10 x 1/2" black screws.



(TIP) You may need the assistance of a second person to align the two edges as you screw the flat Bridging Brackets from underneath the work surface.

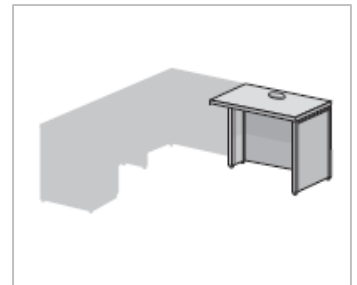
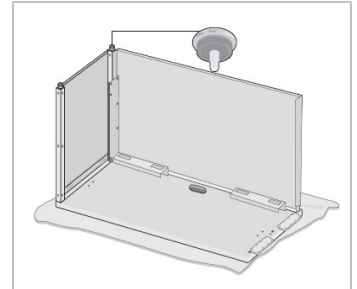
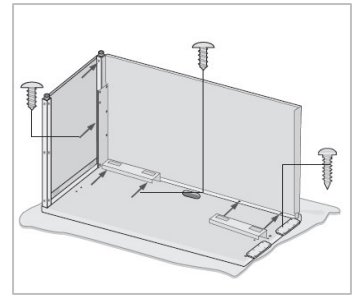

Files & Storage Installation

Box/Box File Pedestal

1. Locate box marked ESP20BM-R/ 2-Box, 1-File drawer Pedestal.
2. Unpack the preassembled Pedestal.
3. Adjust the leveling glides of the Pedestal to be placed underneath the DSRS3M-24-36-FMEP/ Return Surface.
4. Simply slide the Pedestal into the corner of the Left or Right Return.

NOTES: Pedestals are mobile and interchangeable, base on user preference.

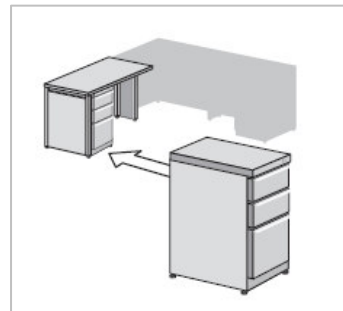

File/File Pedestal

1. Locate box marked ESP20FM-R/ 2-File Drawer Pedestal.
2. Unpack the preassembled Pedestal.
3. Adjust the level glides of the Pedestal to be placed underneath the DSRS3M-24-36-FMEP/ Return Surface.
4. Simply slide the Pedestal into the corner of the Left or Right Return.

NOTES: Pedestals are mobile and interchangeable, base on user preference.

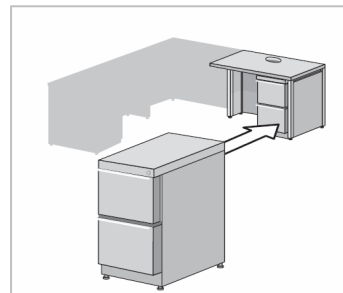

Metro Office Solutions

Workplace Management

For Guidance with the Assembly of Furniture,

Please Contact Customer Service:

1 (866) 450 - 8160

sop@metroofficesolutions.com

